

Renewable Energy for Rural Sustainability: Lessons From China

Aiming Zhou
John Byrne
University of Delaware

Rural electrification is now and will remain an essential element for rural development in China and other developing countries. With more than half of the world's population living in rural communities, lessons for rural renewable energy applications and assessment from China can be very helpful in defining a global sustainable development strategy. This paper describes energy needs in rural China, examines the resource availability of three provinces (Inner Mongolia, Qinghai and Xinjiang in Western China), and evaluates rural energy options and the economics of stand-alone off-grid renewable energy technologies for rural application in this region. An eight-year collaborative effort between several of China's leading energy and environmental research institutes and the Center for Energy and Environmental Policy demonstrates the existence of a viable renewable energy-based strategy to address rural electricity needs in a socially and environmentally sustainable manner.

Key Words: *renewable energy, sustainable development, China energy policy, China environmental policy*

There is now worldwide recognition of the unsustainability of current fossil fuel- and nuclear power-based energy systems (e.g., see, Byrne & Rich, 1992; World Commission of Environment Development, 1987). The environmental risks and uncertainties associated with its operation include climate change, air pollution, and acid rain from fossil fuel combustion; the risks of nuclear reactor accidents; the problem of waste disposal and dismantling of reactors (after their service life is completed); and the danger of weapons proliferation associated with the use of nuclear energy. The common denominator of most policy proposals to pursue a sustainable energy path is

a shift from the current regime to one relying increasingly on renewable energy.

The shift to renewable energy must address not only urban but also rural energy needs. Presently, the majority of the world's citizens (53%) live in rural settings (United Nations, 2001). Greater use of renewable energy resources could provide electricity to more than 2 billion rural people in developing countries who currently lack reliable electricity service (Lenssen, 1993). Decentralized, renewables-based energy service can bring tangible social and economic benefits to rural populations that have been largely neglected by current development patterns. These benefits include the ability to refrigerate food and medicine, the provision of lighting for household needs, evening adult and children's education classes, and power for small electric motors (such as water pumps) to assist rural economic development (Byrne, Shen, & Wallace, 1998; Cabraal, Cosgrove-Davies, & Schaeffer, 1996).

The support of China, which is home to 21% of the world's population and one fourth of its rural residents, will be essential to the success of any proposed strategy for sustainable energy development (for population information, see China Statistical Bureau, 2001). Recent research in China indicates that substantial opportunities exist for the pursuit of renewable energy options in a manner that would be consistent with the country's development needs while also contributing to a global effort to restore a sustainable relation with our atmospheric commons.

China's Rural Energy Needs

Over the past three decades, China has dramatically expanded its power supply, including service to rural areas. As a result of this expansion, the country has

made significant progress in providing rural communities with reliable electricity service. Currently, 62% of China's citizens (or more than 800 million people) live in rural areas, and most (more than 700 million) have access to grid electricity (China Statistical Bureau, 2001). Nonetheless, 70 million rural people have no access to electricity (Li, 2001), and perhaps an equal number experience routine grid failure or other problems with access and use of centralized energy systems. Approximately 4.5 million of this vulnerable rural population is located in the three-province area of Inner Mongolia Autonomous Region (IMAR), Qinghai, and Xinjiang. Because of the prohibitive cost of extending grid services to remote locations, many communities in this area continue to depend on wood burning or diesel/gasoline generators for their daily energy needs. Western China has low population density as well as a high percentage of minority inhabitants with low incomes. In fact, the great majority of the inhabitants in this area of the country live below the national poverty level of U.S.\$100 per capita per year (Poverty-Alleviation Office of State Council, World Bank, & UNDP, 1999).

China has a number of very attractive renewable energy alternatives. According to the government (State Planning and Development Commission & Ministry of Science and Technology, 1994), the nation's wind power potential is approximately 1,600 gigawatts (GW). This is more than 8 times greater than current Chinese electricity generation capacity. Similarly, the prospect for photovoltaic (PV) technology development is strong. Most parts of China receive quite high levels of solar insolation, averaging 1,668 kWh/m² annually (1,200 kWh/m² is considered a reasonably high level of insolation; see State Planning and Development Commission & Ministry of Science and Technology, 1994). Both technologies can bring electricity service to China's non-grid-connected, agriculturally based communities more quickly than conventional grid power for these communities (Byrne et al., 1998).

Economic development is now and will remain a major goal for China. However, is it possible to meet the country's economic needs in a sustainable way? Pursuing an alternative energy path emphasizing renewable energy may be in China's long-term economic and environmental interest. Developing renewable energy alternatives can help the country to spur rural development without further depleting its limited natural resources or harming the environment. At the same time, this strategy enables rural communities to use locally available resources and to create local energy industries to serve their needs, thereby avoid-

ing the numerous social and economic disadvantages of becoming an energy importer.

Western China: An Overview

There are 1 million households in IMAR, Qinghai, and Xinjiang that do not receive grid-electric service (China Statistical Bureau, 2000). An even larger number of households have intermittent grid service. These households include herdsman, farming families, and those with rural commercial businesses. This region has a large population of dispersed households that are difficult to serve with electricity by any means other than renewable energy. A brief description of the social, economic, and renewable energy characteristics of the households and region is provided below.

IMAR

The IMAR of northwestern China was the first national autonomous region established in the country. It is one of the nation's largest administrative regions, with a total area of about 1.183 million km², or one eighth of China's total land area (China Statistical Bureau, 2000). The 1998 estimated population of Inner Mongolia was 23.45 million (China Statistical Bureau, 2000). Three fifths of the population lives on the region's famous grasslands. More than 6% of IMAR's households, representing a population of nearly 1.6 million, lack electricity service. Traditionally, Inner Mongolia's economy has been agricultural, with animal husbandry and forest products providing most of the region's agricultural income. A few highways link Inner Mongolian cities with the rest of China, and domestic air service is available between its larger cities and Beijing. However, much of Inner Mongolia remains isolated.

Per capita annual net income of farmers and herdsman in IMAR in 1999 was about \$241, and herder families in IMAR had higher net incomes per capita than farmers. For comparison, the per capita annual net income of urban residents was about \$574. In IMAR, on average, rural households have 4.1 persons and urban households have 3.2 persons (China Statistical Bureau, 2000).

IMAR is rich in both wind and solar resources. Studies find that wind and solar resources are complementary: During winter months in IMAR when solar energy is low, wind energy is high, whereas in summer months when wind energy is low, solar energy is high

Table 1. Wind and Solar Energy Resources in Western China

	Wind Energy Density (W/m ²)	Hours of Wind Speeds Above 3 m/s per Year	Hours of Wind Speeds Above 6 m/s per Year	Total Solar Insolation per Year (kWh/m ²)	Hours of Sunshine per Year
Resource-rich region as defined by the Chinese Academy of Meteorological Science (Qiu, 1991)	> 150	> 4,000	> 1,500	> 1,500	> 2,800
Inner Mongolia	100-300	4,000-7,000	1,000-4,000	1,400-1,740	2,800-3,400
Qinghai	—	1,168-5,912	184-1,304	1,829-2,014	4,386-4,476
Xinjiang	—	906-2,700	18-876	1,708-2,006	4,406-4,704

Source: Ministry of Agriculture (1999); Qiu (1991).

(Byrne et al., 1998; Shen, 1998). This suggests that wind-PV hybrid systems have the ability to provide stable electricity supplies for rural users.

Qinghai Province

Located in China's Qinghai-Tibetan Plateau, Qinghai Province covers 1/13th of the nation's land area (about 721,000 km²) and is one of China's least populated provinces. Population in 1997 was about 4.96 million (China Statistical Bureau, 1999b), with two thirds living in the countryside. More than 15% of households, representing nearly a million people, are without electricity. Coal, petroleum, and iron ore are the leading natural resources sold by the province to domestic and international markets. The agricultural sector accounts for 17% of Qinghai's gross domestic product.

The per capita annual net income of farmers and herdsmen in Qinghai in 1998 was about \$176. For comparison, the per capita annual net income of urban residents was about \$566. In Qinghai, average rural household size is 5.8 persons, and the urban household average is 3.4 persons (China Statistical Bureau, 1999b).

In Qinghai, only a few counties have rich wind potential. For most parts of the province, the wind resource is modest. However, the solar resource is exceptional. The Chinese Academy of Meteorological Science rates Qinghai's radiation as among the best in the country. Qinghai's solar radiation is better than IMAR (yearly sunshine hours are 20% longer than in IMAR; see Qiu, 1991).

Xinjiang Uygur Autonomous Region

Xinjiang Uygur Autonomous Region is China's largest province, with a total area of about 1.647 mil-

lion km², approximately one sixth of the nation's total land area. The 1995 estimated population of Xinjiang was 16.6 million, with 9.0 million living in rural communities (China Statistical Bureau, 1997). Approximately 11% of the region's households, with 2 million of its residents, have no electricity. Agriculture is the traditional economic base of Xinjiang, but new industries have recently developed to exploit available local resources, which include extensive oil, natural gas, and coal deposits. Needless to say, the very low population density of the region has precluded electrical grid service to one fourth of the population.

Per capita annual net income of farmers and herdsmen in Xinjiang in 1996 was about \$173. For comparison, the per capita annual net income of urban residents was about \$640. In Xinjiang, rural households average about 4.7 persons and urban households about 3.8 persons (China Statistical Bureau, 1997).

The wind resource in Xinjiang is less substantial than in Qinghai or IMAR. However, its solar resource is abundant. In fact, Xinjiang has more sunshine hours than Qinghai on average. Details regarding renewable energy resources in the three provinces are displayed in Table 1.

Energy Performance and Reliability

Renewable energy systems need to be evaluated for performance and reliability. But in rural contexts, these criteria have meanings beyond standard definitions. A broader perspective is required that takes into account social, economic, and environmental factors associated with rural life. The purely technical questions of reliability (e.g., loss of load probability) and bulk energy production cannot be primary concerns for communities whose livelihoods depend on raising animals and farming the land. Rather, performance

and reliability refer to the ability of energy production to meet the needs of rural life in a manner that is consistent with local social organization and economic institutions and that does not harm key environmental resources (such as soil and fresh water supplies) that are essential to livelihoods. Thus, an energy system based on technology that cannot be serviced locally (such as large generators) and that requires fuels that either reduce nutrient regeneration of soils (e.g., the use of certain forms of biomass as energy sources) and/or that reduce air and water quality (e.g., the rising acid levels experienced recently in rural China from the combustion of coal; see Smil, 1993) would be incompatible with rural community needs. Relatedly, an energy system whose service is frequently disrupted because of parts failures that cannot be quickly and locally repaired and that depends on long-distance fuel supply that can be costly and slow (diesel generators in remote areas would be an example) can be regarded as much less reliable than renewable energy technologies, even though the energy sources for the latter are intermittent (see Byrne et al., 1998; Kammen, 1999).

For energy resources to be evaluated in terms of their contribution to sustainable rural development, performance must incorporate local technical capacity, natural resource availability, environmental effects, and full (life-cycle) cost and social impacts as well as energy supply characteristics. Renewable energy options that can meet basic energy needs and promote economic and social development without threatening human health or environmental sustainability will often receive positive evaluations from rural households, especially in comparison to conventional energy alternatives such as generators (and even electrical grid service when supply interruptions are common). Overall, although technical factors of an energy system remain important, our surveys of more than 500 rural Chinese households (see below for details) indicate that social and environmental dimensions of energy use receive at least equal and, in some cases, higher priority.¹

Evaluating Rural Energy Options

To evaluate solar and wind energy alternatives compared to small gasoline and diesel generators (typically less than 500 watts) at the rural household and community scale, the Center for Energy and Environmental Policy (CEEP) constructed a computer simulation model called the “Rural Renewable Energy Anal-

ysis and Design Tool” (RREAD). It is a multi-dimensional simulation tool that evaluates decentralized energy options for rural development in resource, technical, and economic terms (Shen, 1998). RREAD consists of three modules: a data input matrix, a calculation engine, and an output module. The input matrix manipulates six sets of data: wind and solar resource data; load data; system configurations (for solar electric technologies, small wind turbines, and small fossil-fueled generators); full capital and operating costs for all system configurations; financing data; and policy scenario information (e.g., the existence of tax credits, subsidies, and program initiatives to internalize social benefits/costs, etc.). Working through its calculation engine, RREAD analyzes the performance of both renewable energy systems and diesel generators in technical, economic, and also social and environmental terms. It estimates the output of an energy system, assesses the storage requirements (typically satisfied by a battery bank), compares resource availability with load requirements (for renewable energy options), determines energy shortfalls, estimates environmental impacts, characterizes social factors (such as affordability and household energy management challenges), and calculates each system’s leveled economic costs (see Byrne et al., 1998; Shen, 1998).

To conduct a socioeconomic assessment of renewable energy utilization in Inner Mongolia, Qinghai, and Xinjiang, CEEP designed a comprehensive survey questionnaire and a sampling design statistically representing the variety of rural energy users found in western China. Working closely with its Chinese research partners from China’s Ministry of Agriculture, Academy of Science, and the Center for Renewable Energy Development (part of the country’s Energy Research Institute), CEEP surveyed a total of 531 rural households spread over 22 counties throughout western China (Byrne, Wang, Shen, & Zhou, 2001). This survey resulted in a unique database for rural China that for the first time characterized rural energy users, uses, and technologies. The household survey data, combined with socioeconomic information gathered at the county and regional levels, was then evaluated by means of statistical techniques (principally, correlation and regression) to identify social, economic, and technical factors that affect the use of renewable energy options in these areas. Based on the sample data, members of the research team identified key predictors for the purpose of estimating the potential of off-grid renewable energy systems in western China.

The Economics of Stand-Alone Renewable Energy Systems in Western China

Extensive economic analysis of small-scale renewable energy systems has been performed by the China-CEEP research team for a wide array of configurations in western China (see <http://www.nrel.gov/china/publications.html>). Below, we have summarized only a portion of the findings of this research. Two criteria are emphasized: (a) affordability of renewable energy systems for households with modest cash incomes and (b) comparative cost of renewable and nonrenewable energy options in meeting household needs.

Of course, many more criteria would be relevant to a full evaluation. However, affordability and comparative cost address basic constraints on rural households' ability to choose energy options. When renewable energy systems can satisfy these criteria, they are likely to accrue additional benefits (compared to conventional energy technologies). For example, important concerns about compatibility with local traditions, technical interest and skill, and political-economic institutions should be positively addressed by small-scale renewable energy systems. Similarly, adverse environmental impacts are avoided with the uses of solar and wind energy systems, and these technologies can be deployed to support genuinely sustainable, livelihoods-based development. Thus, the selective focus of this section is intended to establish the viability of renewable energy strategies under the relatively less favorable criteria of affordability and comparative cost in the belief that success on these grounds would mean that an even stronger case is consequently available for a rural "soft path" (Lovins, 1977).

Affordability of Stand-Alone Renewable Energy Systems

Typical stand-alone (i.e., not connected to an electric grid) renewable energy systems in use in rural China include modestly sized PV and wind systems intended to provide electricity service to individual homes or small communities (less than 100 households). A common rural PV system involves a solar panel that converts sunlight directly into electricity using semiconductors. A rural wind turbine includes a wind-driven electrical generator, which converts the kinetic energy of wind into electricity through the rotation of the turbine's blades. In addition to electricity generation via a PV panel or a wind turbine, stand-alone renewable energy systems are also equipped

with so-called balance-of-system (BOS) components that include batteries, a charge controller, and an inverter.

Because solar and wind energy are both intermittent sources (i.e., they provide power only at certain times of the day and only at usable rates during certain periods of the year), energy storage represents a critical need. A usual form of storage is a battery bank, often of a very simple type (such as series of car batteries strung together). A PV panel or a wind turbine charges the battery bank during times of resource availability and the stored energy is then withdrawn (with losses) to serve connected loads on demand. To protect the battery bank from being overcharged by the PV panel or wind turbine and to prevent discharging by electric appliances at harmful rates to battery life, a charge controller (also called a power regulator) is typically installed to switch off the current when the battery reaches its charging or discharging limits. Furthermore, to feed regular alternating current (AC)-powered appliances, a direct current (DC)/AC inverter is installed so that the batteries' DC power can be converted to AC.²

A complete small-scale, stand-alone PV or wind system typically has an electricity generation device (a small PV panel or a wind turbine) equipped with a wiring setup and supporting structure as well as the necessary BOS components (i.e., the battery bank, the charge controller, and the DC/AC inverter). Less common but of increasing interest are small-scale PV/wind hybrid systems, which are equipped with both a PV panel and a wind turbine. A typical stand-alone renewable energy system design is illustrated in Figure 1.

The appropriate size of rural PV, wind, and hybrid systems was determined through extensive interviews with households in western China. Broadly, three levels of daily electricity demand were found to apply among the highly diverse sample of households we studied (see Figure 2). Audits of current energy-using equipment in surveyed households and a questionnaire administered in person by our research team asking households about their expectations of future energy needs enabled us to identify daily household energy use patterns and loads. These information sources yielded estimates of rural household daily electricity needs of between 300 Wh and 1.6 kWh. Average rural family size in the three provinces under study is 4.4 (average family size in China is 3.65 persons; see China Statistical Bureau, 1999a).³

Some rural families—largely with young heads of household and modest incomes—seek electricity

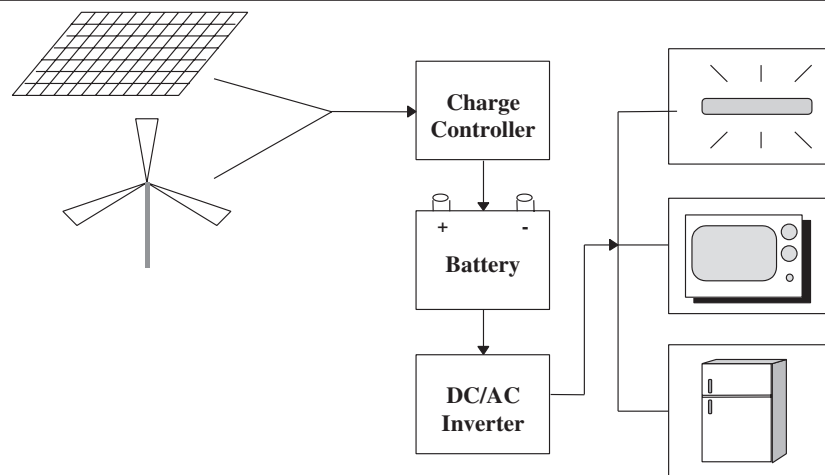

Figure 1. Conceptual Drawing of a Stand-Alone Hybrid Renewable Energy System

Note: AC = alternating current; DC = direct current.

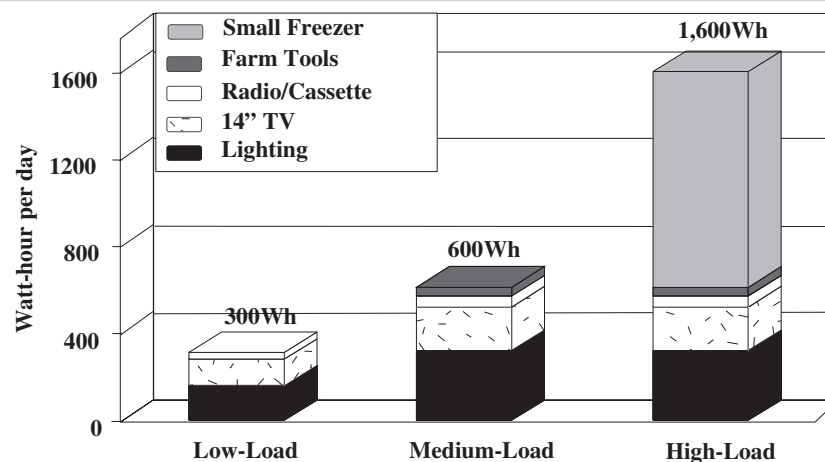

Figure 2. Profile of Daily Household Electricity Demand in Western China

mainly for lightning and communications needs, resulting in average daily loads of approximately 300 Wh. Large families and those with higher incomes desire electricity to power certain farm tools (including small pumps and dryers), reaching daily consumption levels of 600 Wh or more. Upper income households (by rural Chinese standards, this would mean more than U.S.\$1,000 in yearly cash earnings) can acquire small freezers (whose principal use is to refrigerate medicine and preserve certain foods).

More than 20 configurations of PV, wind, and hybrid systems can be suitable for rural households of the scales depicted in Figure 2 above:

PV systems: 22Wp-120Wp;
Wind systems: 100W-300W;

Hybrid systems: 35Wp PV-100W Wind to 60Wp PV-100W Wind; 35Wp PV-200W Wind to 100Wp PV-200W Wind; and 60Wp PV-300W Wind to 120Wp PV-300W Wind.

All systems use Chinese-made PV arrays, except for the 120Wp PV system, which is typically U.S. technology. Wind systems are all made by local Chinese manufacturers. We were unable to identify U.S., European, or Japanese companies that could offer wind turbines at such small power ratings, which is an indicator that rural energy needs are better known technically in developing countries. Batteries and charge controllers are also available from Chinese suppliers, but DC/AC inverters are frequently imported. In part because the bulk of the equipment for small-scale

Table 2. Levelized Costs for Photovoltaic (PV), Wind, and Hybrid Systems in Inner Mongolia Autonomous Region (IMAR), Xinjiang, and Qinghai

System	Province	Output Range (kWh year ⁻¹)	Levelized Cost (\$ kWh ⁻¹)
Wind only	IMAR	196-640	0.25-0.37
	Qinghai	27-342	0.31-1.51
	Xinjiang	8-212	0.46-4.11
PV only	IMAR	37-225	0.70-0.94
	Qinghai	47-328	0.52-0.78
	Xinjiang	55-400	0.45-0.68
PV-wind hybrids	IMAR	256-860	0.30-0.50
	Qinghai	102-663	0.36-1.02
	Xinjiang	95-538	0.46-1.16
Gas/diesel GenSet	All	481-554	1.09-1.19

renewable energy systems can be made in China, system costs average less than \$7.39 to \$7.55/Wp for PV configurations, \$1.70 to \$2.78/W for wind generators, and \$2.28 to \$3.54/W for hybrid systems. Although the China-CEEP partnership was able to secure a U.S. Department of Energy grant that created a revolving loan fund for the pilot project, few financing options exist for China's rural communities.

Despite the absence of loan funds, our survey of western Chinese communities indicates that most (but not all) rural households believe they can afford small-scale PV, wind, or hybrid systems. Stand-alone PV systems range in cost from \$150 to \$900, wind systems from \$225 to \$600, and hybrids from \$450 to \$1,300. Household savings for 2 to 5 years (depending on income level) would typically be required to accumulate sufficient funds for the purchase of the renewable energy systems analyzed by the China-CEEP team.

Importantly, it is evident that development of a renewable energy sector to meet rural needs is underway in China. Currently, there are more than 60,000 small wind turbines operating in IMAR, and approximately 400,000 small PV systems are in use across the three provinces (Li, 2001). These systems have been manufactured by a growing rural industry in western China specializing in small-scale renewable energy systems.

Comparative Cost Analysis

Cost comparisons of household-scale PV, wind, PV-wind hybrid, and conventional fossil-fueled small generators were prepared for 11 counties across the three provinces. Assumptions and parameters needed

for a cost analysis of these systems are extensive and are described in the main report to National Renewable Energy Laboratory (Byrne et al., 2001). Standard analytical techniques were used to estimate levelized costs.⁴ This estimation procedure enables a full, life-cycle cost comparison of systems. Each technology was evaluated at its maximum energy (kWh) generation capacity. To compare the economics of different technologies, we based our analysis on the combination of installed capital costs and operating, fuel, and maintenance expenditures over the lifetimes of all systems.⁵

Our analysis indicates that the least cost configuration for household-scale, stand-alone generation differs among the counties and provinces (see Table 2). Wind-only and hybrid systems are the least cost options for IMAR, whereas PV-only and hybrid systems are the most cost-effective choice for Qinghai and Xinjiang.

Importantly, in all three provinces, renewable energy systems are economically superior to conventional energy options, even before social and environmental benefits are included (Byrne et al., 2001).

Scaling Up Rural Sustainability

To estimate the potential scale of a renewable energy-based rural society, a logistic regression model⁶ was created that combined socioeconomic data for western China with estimates of levelized costs of renewable systems.

In this approach, household income and expressed interest in purchasing small-scale renewable energy systems are matched with resource and system output data to identify the proportion of households in each province who would prefer different configurations of energy systems for their families. Based on this socioeconomic approach, the China-CEEP team estimated the potential of a renewable energy-based rural development sector for IMAR, Qinghai, and Xinjiang (see Table 3).

The potential for local renewable energy systems for stand-alone PV and wind systems in IMAR, Xinjiang, and Qinghai appears to be substantial.

- The potential for PV systems: Our analysis suggests that in the province of IMAR, about 93% of rural, non-grid-connected households would have an interest in and the ability to own a PV system, whereas the figure for Xinjiang and Qinghai is 92% and 95%, respectively.

Table 3. Market Size of Renewable Energy System in Inner Mongolia Autonomous Region (IMAR), Xinjiang, and Qinghai

	Total Units That Could Be Purchased			Total Capacity That Could Be Installed (megawatts)	
	Photovoltaic	Wind	Hybrid System	Photovoltaic	Wind
IMAR	195,793	200,867	136,234	9.79	20.09
Xinjiang	189,990	164,444	152,900	9.50	16.44
Qinghai	58,698	57,237	43,325	2.93	5.72

- The potential for wind systems: The interest in and ability to own a wind system in IMAR is about 95% of rural households without access to grid electricity. In Xinjiang and Qinghai, approximately 79% and 93%, respectively, of rural off-grid households can afford and have a preference for small wind turbines.
- The potential for hybrid systems: The local market for hybrid systems is smaller in the three provinces than for stand-alone PV and wind systems. Our research suggests that in IMAR, Xinjiang, and Qinghai, 65%, 73%, and 70%, respectively, of rural off-grid households would have an interest in and ability to purchase hybrid systems.

Overall, the China-CEEP team estimates that more than 850,000 rural households potentially would purchase renewable energy systems with a three-province scale of 22 MW of PV and 42 MW of wind installed capacity—all as small, decentralized household and community systems (Byrne et al., 2001). This would mean that greater than 90% of the rural population currently without access to electricity in the three provinces would be served. Obviously, at this rate of service, renewable energy would constitute the core means for meeting the electricity needs of rural life in the region.

Conclusion

Rural electrification is now and will remain an essential element for rural development in China and other developing countries. The China-CEEP research team's 8-year effort demonstrates the existence of available renewable energy options to address rural electricity needs in western China in a socially and environmentally sustainable manner.

China's success in this regard offers valuable lessons for the pursuit of a sustainable rural development strategy. However, the challenges of building a sustainable rural energy future remain substantial. There are important barriers preventing the local commercialization of these decentralized technologies, especially the absence of well-developed, affordable loan services that are sensitive to rural community needs. Perhaps the most significant barrier, however, is the entrenched bias toward industrial-urban models of development that shape international and national policy. Without a paradigm shift in this regard, the potential for rural sustainability may go unmet.

Notes

1. Naturally, affordability is ranked high (see section Affordability of Stand-Alone Renewable Energy Systems) because rural households rarely have significant cash incomes.

2. Although it is not always necessary to include an inverter, the prevalence of alternating current-powered appliances and lighting equipment makes this a practical necessity.

3. For comparison, the average American family of 3.14 persons uses 30 to 50 kWh of electricity per day (U.S. Census Bureau, 2001).

4. *Levelized costs* are defined as the total discount costs of energy systems standardized over the evaluation period by obtaining a levelized annual discount factor using the annuity concept in financial analysis.

5. Photovoltaic (PV) systems have an expected lifetime of 15 years, whereas wind turbines normally last 10 years. Battery lifetime, as claimed by manufacturers, is 3 years for a wind-only or a small PV/wind hybrid system, 4 years for a PV-only system, and 5 years for a large PV/wind hybrid system. Field experience, however, suggests that Chinese batteries normally last only 1 year for wind and small hybrid systems and 2 years for PV and large hybrids. The charge controllers and the direct current/alternating current inverters typically have lifetimes of 10 years.

6. A logistic regression model (LRM) is appropriate when a dichotomous dependent variable (such as household preference for a renewable or nonrenewable energy system) is present. The probability of a dichotomous series of outcomes is treated as logarithmic. By using a mathematical method called maximum likelihood

estimation, an LRM can be created to produce accurate probability estimates of dichotomous outcomes.

References

- Byrne, J., & Rich, D. (1992). *Energy and Environmental Policy: Vol. 6. Energy and environment: The policy challenge*. New Brunswick, NJ: Transaction Publishing.
- Byrne, J., Shen, B., & Wallace, W. (1998). The economics of sustainable energy for rural development: A study of renewable energy in rural China. *Energy Policy*, 26(1), 45-54.
- Byrne, J., Wang, Y.-D., Shen, B., & Zhou, A. (2001). *Off-grid renewable energy options for rural electrification in western China*. Newark: University of Delaware, Center for Energy and Environmental Policy.
- Cabraal, A., Cosgrove-Davies, M., & Schaeffer, L. (1996). *Best practice for photovoltaic household electrification programs: Lessons from experiences in selected countries* (World Bank Technical Paper No. 324). Washington, DC: The World Bank.
- China Statistical Bureau. (1997). *Xinjiang statistical yearbook, 1996*. Beijing: China Statistical Publishing House.
- China Statistical Bureau. (1999a). *Chinese statistical yearbook, 1998*. Beijing: China Statistical Publishing House.
- China Statistical Bureau. (1999b). *Qinghai statistical yearbook, 1998*. Beijing: China Statistical Publishing House.
- China Statistical Bureau. (2000). *Inner Mongolia statistical yearbook, 1999*. Beijing: China Statistical Publishing House.
- China Statistical Bureau. (2001). *Data communiqué of the Fifth National Census, China*. Beijing: Chinese Statistical Publishing House.
- Kammen D. (1999). Bringing power to the people: Promoting appropriate energy technologies in the developing world. *Environment*, 41(5).
- Lenssen, N. (1993). Providing energy in developing countries. In L. R. Brown et al. (Eds.), *State of the world 1993* (pp. 109-119). New York: W. W. Norton.
- Li, J. (2001). *Commercialization of solar PV systems in China*. Beijing: China Environmental Science Press.
- Lovins, A. (1977). *Soft energy paths: Toward a durable peace*. Cambridge, MA: Ballinger.
- Ministry of Agriculture. (1999). *Materials on wind and solar energy resources statistics in western China, 1999*. Beijing: China Statistical Publishing House.
- Poverty-Alleviation Office of State Council, World Bank, & UNDP. (1999). *China rural areas poverty-alleviation investigation report*. Retrieved from www.cnspp.org.cn/ZTBD/FPZLYT
- Qiu, D. (1991). *Rural energy integrated planning and application*. Beijing, China: Tsinghua University Press.
- Shen, B. (1998). *Sustainable energy for the rural developing world: The potential for renewable energy to assist developing countries in pursuing sustainable rural development*. Doctoral dissertation, University of Delaware, Newark.
- Smil, V. (1993). *China's environmental crisis*. London: M. E. Sharpe.
- State Planning and Development Commission & Ministry of Science and Technology. (1994). *China's Agenda 21—White paper on China's population, environment and development in the 21st century*. Beijing: China Environmental Science Press.
- United Nations. (2001). *World population monitoring 2001—Population, environment and development*. New York: United Nations Publication Office.
- U.S. Census Bureau. (2001). *Households and families: 2000*. Washington, DC: National Technical Information Service.
- World Commission of Environment Development. (1987). *Our common future*. New York: Oxford University Press.

Aiming Zhou is a Ph.D. candidate and research associate at the Center for Energy and Environmental Policy, University of Delaware. He previously worked as a research fellow at the Center for Renewable Energy Development of Energy Research Institute in China.

John Byrne is director and professor of the Center for Energy and Environmental Policy at the University of Delaware. He serves as coexecutive director of the Joint Institute for Sustainable Energy and Environmental Future, headquartered in Seoul, Korea. Address correspondence to the Center for Energy & Environmental Policy, University of Delaware, Newark, DE 19716-7301; phone: (302) 831-8405; e-mail: jbyrne@strauss.udel.edu.